



# Easidew DryCheck OnLine Dew-Point Hygrometer User's Manual



Please fill out the form(s) below for each instrument that has been purchased.

Use this information when contacting Michell Instruments for service purposes.

Instrument	
Code	
Serial Number	
Invoice Date	
Location of Instrument	
Tag No	

Instrument	
Code	
Serial Number	
Invoice Date	
Location of Instrument	
Tag No	

Instrument	
Code	
Serial Number	
Invoice Date	
Location of Instrument	
Tag No	



## Easidew DryCheck

For Michell Instruments' contact information please go to  
[www.michell.com](http://www.michell.com)

© 2017 Michell Instruments

This document is the property of Michell Instruments Ltd. and may not be copied or otherwise reproduced, communicated in any way to third parties, nor stored in any Data Processing System without the express written authorization of Michell Instruments Ltd.

---

## Contents

Safety .....	vi
Electrical Safety .....	vi
Pressure Safety .....	vi
Toxic Materials .....	vi
Repair and Maintenance .....	vi
Calibration .....	vi
Safety Conformity .....	vi
Abbreviations .....	vii
Warnings .....	vii
1 INTRODUCTION .....	VIII
1.1 General .....	viii
1.2 Features .....	viii
2 INSTALLATION .....	1
2.1 Unpacking the Instrument .....	1
2.2 DryCheck System Configuration .....	2
2.3 Monitor .....	2
2.4 Monitor Panel Layout .....	3
2.5 Function Keys .....	5
2.6 Mounting .....	5
2.7 Power Supply .....	5
2.8 Signal Output Connections .....	6
3 OPERATION .....	8
3.1 General Operational Information .....	8
3.2 Preparation For Operation .....	9
3.2.1 First Time Operation .....	9
3.3 System Alarms .....	10
3.3.1 Alarm Switching Logic (Default) .....	10
3.3.2 Reversal of Alarm Switching Logic .....	10
3.3.3 Alarm Level Set-Up .....	12
3.3.4 Re-Transmitted Output Current Range Set-Up .....	13
3.4 Operating Temperature / ppm <sub>v</sub> Range .....	14
3.4.1 Temperature Range Default .....	14
3.4.2 Span and Unit Settings .....	15
3.4.3 Alarm Set-Point Limit Configuration .....	16
3.4.4 Scale Units to ppm <sub>v</sub> Set-Up .....	17
3.4.5 Monitor Limits When Unit Scaled to ppm <sub>v</sub> .....	18
3.5 Digital Communication Parameters Set-Up .....	19
3.6 Monitor – Reading the Displayed Value Using Modbus RTU Over RS232 .....	21
4 GOOD MEASUREMENT PRACTICE .....	22
5 MAINTENANCE .....	23
5.1 General Maintenance Guidelines .....	23
5.2 Calibration .....	23
5.3 Transmitter Maintenance .....	23
5.4 Inspection/Cleaning .....	24
5.5 Fault Conditions .....	25

## Figures

Figure 1	Easidew DryCheck.....	viii
Figure 2	Unpacking Method.....	1
Figure 3	Gas Flow Diagram .....	2
Figure 4	Monitor Panel Layout .....	3
Figure 5	Alarm and Communications.....	6
Figure 6	Monitor Rear Panel Connections .....	7
Figure 7	Typical Display .....	9
Figure 8	Change Alarm Switching Logic.....	11
Figure 9	Set-up Alarm Levels.....	12
Figure 10	Configure Analog Output.....	13
Figure 11	Span and Unit Settings .....	15
Figure 12	Set-up Alarm Set-Point Limits .....	16
Figure 13	Set-up Monitor (to read ppm <sub>v</sub> ).....	18
Figure 14	Set-up Data Communications Parameters.....	20
Figure 15	Sensor Removal .....	23
Figure 16	Inspection/Cleaning.....	24
Figure 17	System Drawings.....	29

## Tables

Table 1	Monitor Front Panel Controls and Indicators .....	4
Table 2	Function Keys.....	5
Table 3	Summary of Electrical Connections .....	7

## Appendices

Appendix A	Technical Specifications.....	27
Appendix B	System Drawing .....	29
Appendix C	Quality, Recycling & Warranty Information.....	31
Appendix D	Return Document & Decontamination Declaration.....	33
Appendix E	EU Declaration of Conformity.....	35

## Safety

The manufacturer has designed this equipment to be safe when operated using the procedures detailed in this manual. The user must not use this equipment for any other purpose than that stated. Do not apply values greater than the maximum value stated.

This manual contains operating and safety instructions, which must be followed to ensure the safe operation and to maintain the equipment in a safe condition. The safety instructions are either warnings or cautions issued to protect the user and the equipment from injury or damage. Use competent personnel using good engineering practice for all procedures in this manual.

## Electrical Safety

The instrument is designed to be completely safe when used with options and accessories supplied by the manufacturer for use with the instrument.

## Pressure Safety

DO NOT permit pressures greater than the safe working pressure to be applied to the instrument. The specified safe working pressure is 10 barg (145 psig).

## Toxic Materials

The use of hazardous materials in the construction of this instrument has been minimized. During normal operation it is not possible for the user to come into contact with any hazardous substance which might be employed in the construction of the instrument. Care should, however, be exercised during maintenance and the disposal of certain parts.

## Repair and Maintenance

The instrument must be maintained either by the manufacturer or an accredited service agent. Refer to [www.michell.com](http://www.michell.com) for details of Michell Instruments' worldwide offices' contact information.

## Calibration

The recommended calibration interval for this instrument is 12 months unless it is to be used in a mission-critical application or in a dirty or contaminated environment in which case the calibration interval should be reduced accordingly. The instrument should be returned to the manufacturer, Michell Instruments Ltd., or one of their accredited service agents for re-calibration.

## Safety Conformity

This product meets the essential protection requirements of the relevant EU directives. Further details of applied standards may be found in the product specification.

## Abbreviations

The following abbreviations are used in this manual:

AC	alternating current
barg	pressure unit (=100 kP or 0.987 atm)
°C	degrees Celsius
°F	degrees Fahrenheit
dp	dew point
Hz	Hertz
mA	milliampere
NI/min	normal liters per minute
psig	pound(s) per square inch (gauge)
V	volts
VA	volt-ampere

## Warnings

The following general warnings listed below are applicable to this instrument. They are repeated in the text in the appropriate locations.



**Where this hazard warning symbol appears in the following sections, it is used to indicate areas where potentially hazardous operations need to be carried out.**

## 1 INTRODUCTION

### 1.1 General

The Easidew DryCheck is an instrument designed for continuous, online measurement of moisture content in compressed air and other gases over an operating range of over either -100 to +20°Cdp (-148 to -4°Fdp) / -60 to +60°Cdp (-76 to 140°Fdp) / -50 to +50°Cdp (-58 to 122°Fdp). The Easidew DryCheck is protected within an IP65-rated, wall-mounted enclosure with a hinged lid. The lid allows access to a panel-mounted, process indicator with a °C dew-point display.



Figure 1 *Easidew DryCheck*

### 1.2 Features

Integrated instrument and sampling system

- Simple installation
- Wide measurement range
- Dew point or moisture content
- Analog output, display and alarm
- IP65 (NEMA 4x) enclosure

## 2 INSTALLATION

### 2.1 Unpacking the Instrument



It is essential that the connection of electrical and gas supplies to this instrument be undertaken by competent personnel.

The Easidew DryCheck instrument and its accessories are packed into a box and the method of unpacking is shown as follows:

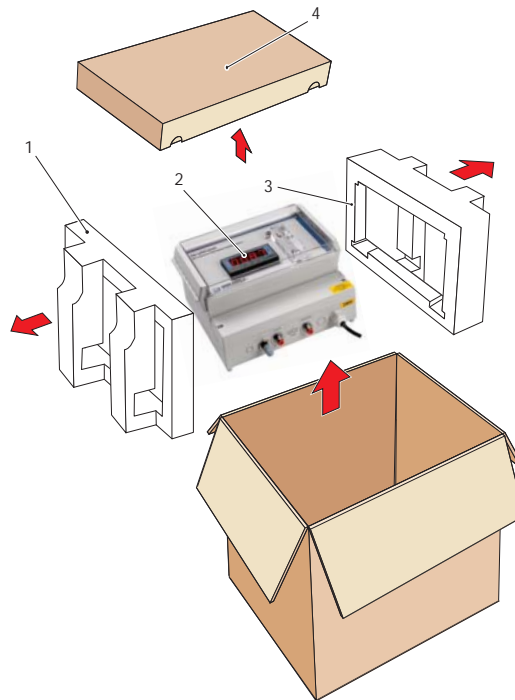

Figure 2 *Unpacking Method*

Open the box and unpack carefully (see *Figure 2*) :

1. Remove the accessories box (4).
2. Lift out the instrument (2) together with its end packing pieces (1) and (3).
3. Remove the end packing pieces and set the instrument down at the site of installation.

**Save all the packing materials for the purpose of returning the instrument for re-calibration or any warranty claims.**

The accessories box (4) should contain the following items:

- Traceable calibration certificate
- User manual
- Country specific power cable

On delivery please check that all the standard components shown above are present in the packing box. Immediately report any shortages to Michell Instruments.

2.2 DryCheck System Configuration

The DryCheck sampling system includes a 0.3 µm particulate filter element, a monolithic sampling block to house the transmitter, and a valve and flowmeter for setting the sample flow. The filter element is easily replaceable to ensure that the sensor is protected. All components are rated to 1 MPa (10 barg) and the DryCheck can be configured for measurement of dew point at either system or atmospheric pressure.

All components are housed in a rugged IP65 (NEMA 4x) rated polycarbonate case. This can easily be wall mounted at a convenient point close to the gas sample.

A clear cover protects the display and the sample flowmeter. Gas connection (gas in and gas out) is provided using quick connect push fittings suitable for use with 6mm (1/4") OD Teflon tubing. Mains power input and connection to the 4-20 mA analog output and the two user programmable voltage free relay contacts are all easily accessible behind the lower panel.

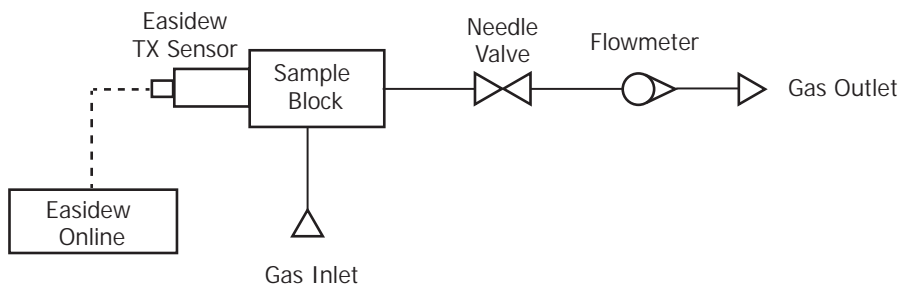

Figure 3 Gas Flow Diagram

**NOTE: The DryCheck is designed to measure dew point at standard instrument air pressure or 7 barg.**

A barometric version is available on request, please contact Michell Instruments (see [www.michell.com](http://www.michell.com) for contact details).

2.3 Monitor

The controls and indicators associated with the Easidew DryCheck are located on the front panel of the monitor.

Connections to the monitor and the external power supply are made to the rear panel of the monitor and are replicated on two terminal blocks.

Figure 4 shows the layout of these controls and Tables 1 and 2 describe their respective operational functions.

Dew-point temperature units are displayed by one of the two LEDs located to the left of the display. On delivery, °Cdp is set-up as standard. If required, the units can be changed to °F. The method of configuring the unit for °F is described in Section 3.4.

Optionally, the instrument can be set-up to read dew point in parts per million (ppm<sub>v</sub>), range 0 to 3000 ppm<sub>v</sub>. This option requires the transmitter to be set-up for ppm<sub>v</sub> either at the time of ordering or subsequently via Michell application software. **NOTE: No specific ppm<sub>v</sub> LED indicator is provided on the monitor; ppm<sub>v</sub> is selected if neither the °Cdp nor the °Fdp temperature indicators are illuminated.**

Two temperature alarm indications are provided by two LEDs located on the right hand side of the display. These are marked **ALr1** (low) and **ALr2** (high). Access to the alarm relay contacts is provided on the rear panel. The connection for the **ALr2** contact is shown in Section 2.8.

**NOTE:** Every monitor is factory fitted with 2 alarm relays as standard. On the DryCheck product only 1 relay (ALr2) is brought to the terminal strip.

## 2.4 Monitor Panel Layout

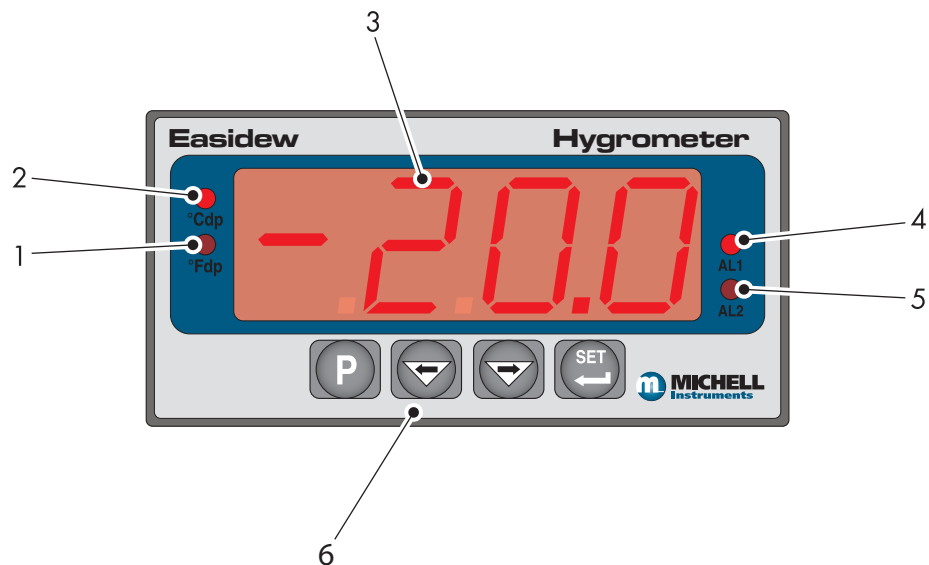

Figure 4 *Monitor Panel Layout*

Item	Description
1	<p><b>°Fdp</b></p> <p>When illuminated, this LED indicates that the displayed dew-point reading is in degrees Fahrenheit.</p> <p><b>NOTE: If neither the °Fdp or °Cdp LED is lit, ppm<sub>v</sub> is selected.</b></p>
2	<p><b>°Cdp</b></p> <p>When illuminated, this LED indicates that the displayed dew-point reading is in degrees Celsius.</p> <p><b>NOTE: if neither the °Cdp nor °Fdp LED is lit, ppm<sub>v</sub> is selected.</b></p>
3	<p><b>Main dew-point temperature display</b></p> <p>Flashes to alternately indicate <b>ErrL</b> (error low) and temperature reading for low temperatures under-range (lower than -100°Cdp (-148°Fdp) or -129.9°Cdp (199.9°Fdp) for an open loop condition).</p> <p>Flashes to alternately indicate <b>ErrH</b> (error high) and temperature reading for high temperature over-range.</p>
4	<p><b>ALr1 Output</b></p> <p>Only available directly from the back of the Monitor panel.</p>
5	<p><b>ALr2</b></p> <p>When illuminated this LED indicates that the dew-point temperature programmed for Alarm 2 has exceeded the programmed threshold. Under these conditions the alarm relay changeover contacts associated with this alarm will change state and will remain in this state until the temperature moves back to within the programmed operational limit.</p> <p>Alarm 2 is usually allocated to the High Alarm setting.</p> <p>These changeover relay contacts are rated at 240 V, 3 A and are connected as shown in Section 2.8.</p> <p>Section 3.4.3 details the setting up of <b>ALr2</b> trip points.</p>
6	<div style="display: flex; align-items: center;">  <div style="margin-left: 10px;"> <p>The four function keys are used for setting up the monitor.</p> <p>Table 2 describes the operation of the keys.</p> </div> </div>

Table 1 Monitor Front Panel Controls and Indicators

## 2.5 Function Keys

The function key panel is shown in *Figure 4*.

Table 2 describes the operation of the keys.



Item	Description
	<b>P (Program) key</b> This key is used to access the programming menus and to select sub-menus within the list.
	<b>⇐ Left arrow (decrement) key</b> This key is used to access sub-menus and, within individual sub-menus, to decrease the numeric value of the selected parameter.
	<b>⇒ Right arrow (increment) key</b> This key is used to access sub-menus and, within individual sub-menus, to increase the numeric value of the selected parameter.
	<b>SET key</b> Depending upon the context, this key is used to access the set value of the selected process field and as an Accept key for new parameter values.

Table 2 Function Keys

## 2.6 Mounting

The instrument is designed for wall or panel-mounting and has 3 fixing points. Mounting fasteners are not supplied. See the System Drawing in Appendix B for wall-mount fixing points.

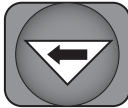
## 2.7 Power Supply

A single-phase mains power supply of 100 to 240 V (-15% / +10%), 50/60 Hz, 6 VA is required to power the Easidew DryCheck.

Loosen the 2 screws and remove the access cover at the lower front of the instrument (*Figure 5*). A cable gland is provided, through which the power supply cable should be passed.

The power supply cable should then be connected to the terminal strip which is mounted on the right hand side.

Terminals are marked:

<b>7</b>	<b>8</b>	<b>9</b>	<b>10</b>	<b>11</b>	<b>12</b>
Earth	Not Used	Neutral	Not used	Live	Not used

## 2.8 Signal Output Connections

The Easidew DryCheck has 1 signal output Alarm 2 (ALr2) and the re-transmitted input signal (4-20 mA or 0-20 mA current loop signal depending upon instrument configuration).

Loosen the 2 screws and remove the access cover at the lower front of the instrument (Figure 5). The signal cable should then be connected to the terminal strip which is mounted on the left hand side.

Terminals are marked:

For Alarm Connections				For mA Signal Connections	
1	2	3	4	5	6
Normally Closed	Normally Open	COM	Not used	+ mA	- mA



Figure 5 Alarm and Communications



The signal outputs will be connected to external systems that can potentially influence the operation of the process.

Alarm level signals could be at mains potential so it is essential that, before connecting these signal lines, checks are made to ensure that these inputs are not live and that it is safe to handle them.

### Alarm Output

Alarm 2 comprises a set of changeover contacts. Connect incoming signal lines to terminal 3 (common), terminal 2 (normally open) and terminal 1 (normally closed).

Figure 6 shows the relevant rear panel connections. Table 3 shows a summary of all the electrical connections to the monitor.

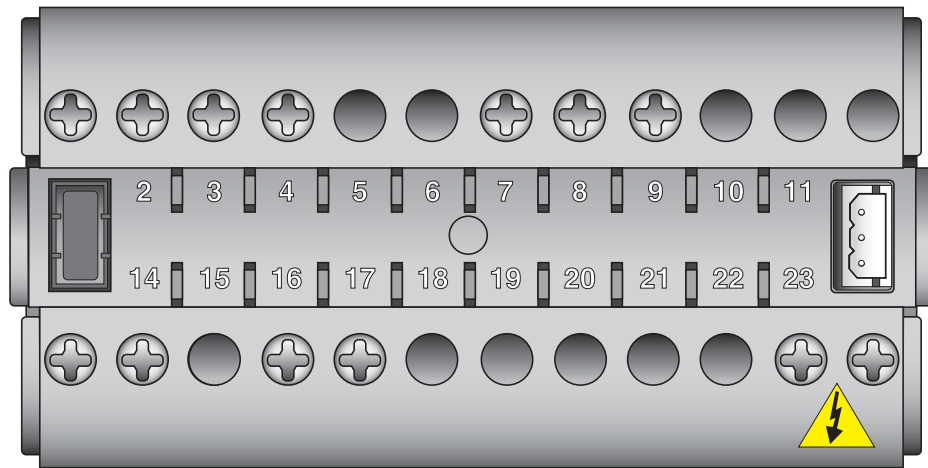

Figure 6 Monitor Rear Panel Connections

**Re-transmission Output**

The re-transmission output is current sourcing. Connect the positive output to terminal 14 and the negative output to terminal 13. Use appropriately colored wires eg. red (positive), black (negative).

Terminal	Wire Color	Signal	Supply Information
1	Blue	0 V (GND)	
3	Green	4-20 mA loop current	Default 4-20 mA
4	Red	Transmitter loop supply (+ve)	+24 V DC w.r.t. terminal 1
7	User defined	ALr2 (normally closed)	
8	User defined	ALr2 (normally open)	
9	User defined	ALr2 (common)	
13	User defined	Current loop out (-ve)	Default 4-20 mA
14	User defined	Current loop out (+ve)	Default 4-20 mA
16	User defined	ALr1 (common)	
17	User defined	ALr2 (normally open)	
23 (AC Version)	Blue	Power in (neutral)	100 – 240 V, 50/60 Hz
24 (AC Version)	Brown	Power in (live)	100 – 240 V, 50/60 Hz
23 (DC Version)	Black	Negative (-)	0 V
24 (DC Version)	Red	Positive (+)	24 V
<p><b>NOTE: There are no terminals in positions 5, 6, 10, 11, 12, 15, 18, 19, 20, 21 and 22</b></p>			

Table 3 Summary of Electrical Connections

### 3 OPERATION

As supplied, the instrument is ready for operation and has been set-up with default parameters. This section describes both the general operation of the instrument and the method of setting it up and changing the default parameters should this become necessary.

The default parameters are as follows:

- Span -100 to +20°Cdp (-148 to +68°Fdp), -60 to +60°Cdp (-76 to 140°Fdp) / -50 to +50°Cdp (-58 to 122°Fdp) or 0 to 3000 ppm<sub>v</sub>
- Temperature units °Cdp
- Current loop input, 4-20 mA (7.5°C/mA or 13.5°F/mA)
- Re-transmission current loop output, 4-20 mA (7.5°C/mA or 13.5°F/mA)
- Alarm 2 set-point -40°Cdp (-40°Fdp)

For the supplied dew-point transmitter, the span and current loop input setting should not be changed. The span will require changing if the instrument is to be ranged in °F, if a different transmitter is employed, if the user chooses to re-range the transmitter or if ppm<sub>v</sub> is selected.

The instrument must also have been installed as detailed in Section 2 and connected to a sample gas supply that is representative of the process being monitored.

#### 3.1 General Operational Information

Operation of the Easidew DryCheck is completely automatic and, once set-up, requires little or no operator intervention.

The dew-point transmitter is designed to operate in a flowing gas stream of between 1 to 5 NI/min (2.1 to 10.6 scfh) when mounted in a sample block, at operating pressures up to a maximum of 10 barg (145 psig).

The sample gas is taken into the sample block via the Gas In port and, in flowing through the sample block, comes into contact with the dew-point transmitter which, in turn, produces a current loop output signal proportional to the measured dew-point temperature. This output signal is converted to a dew-point temperature reading by the monitor.

If necessary, gas flow through the sample block must be controlled outside the instrument, typically by means of a needle valve located in the sample gas input line.

## 3.2 Preparation For Operation

### 3.2.1 First Time Operation

To commence operation, proceed as follows:

1. Check that electrical power supply and the relevant analog and alarm outputs are connected to external systems as required and as described in Section 2.8.
2. Check that the gas sample flow rate through the sample block, or the pipeline in which the transmitter is located, is within the operational limits. (Adjust any external flow control valves, located in the gas sample input line to the instrument to achieve required flow rate.)
3. Switch on the power supply to the instrument. The instrument display will now come on, typically showing the default parameters and units as detailed in *Figure 7*.

The instrument is now operational and after a few seconds, in which all the segments of the display are tested, the monitor will display the measured dew-point temperature as a steady reading within the range  $-100$  to  $+20^{\circ}\text{Cdp}$  ( $-148$  to  $+68^{\circ}\text{Fdp}$ ),  $-60$  to  $+60^{\circ}\text{Cdp}$  ( $-76$  to  $140^{\circ}\text{Fdp}$ ) /  $-50$  to  $+50^{\circ}\text{Cdp}$  ( $-58$  to  $122^{\circ}\text{Fdp}$ ) or  $0$  to  $3000$  ppm<sub>v</sub> depending upon how the instrument has been set-up. The default setting is  $^{\circ}\text{C}$ .

In the absence of any error indications the instrument will now be operational using the default parameters.



Figure 7 *Typical Display*

If the display is flashing, a fault condition exists. The following operational error conditions may be encountered:

**ErrL** - If the display is alternately flashing (e.g.) **ErrL** and **-103.3**, this indicates that the measured dew point is outside the lower operational limit ( $-100^{\circ}\text{Cdp}/-148^{\circ}\text{Fdp}$ ).

If the display is alternately flashing **ErrL** and **-129.9** (**-199.9** if set-up to read temperature in  $^{\circ}\text{F}$ ), this could be an indication that the input current loop to the monitor is open or that there may be a transmitter fault. Check that the transmitter is wired correctly as detailed in Section 2.8.

**ErrH** - If the display is alternately flashing (e.g.) **ErrH** and **021.4**, this indicates that the measured dew point is outside the upper operational limit ( $+20^{\circ}\text{Cdp}/+68^{\circ}\text{Fdp}$ ).

### 3.3 System Alarms

#### 3.3.1 Alarm Switching Logic (Default)

The Easidew DryCheck has one alarm output. As supplied, the default alarm set-point and the alarm switching logic are as follows (the default temperature units are degrees Celsius):

**Alarm 2** (High Alarm) is set to switch **ON** when the temperature reading is higher (gas wetter) than its set-point value. For the default set-points therefore, the operation of this alarm would be as follows:

Alarm 2      Temp < -40 Alarm 2 = OFF

Temp > -40 Alarm 2 = ON

Depending upon the application, if required, it is possible to reverse the switching logic for either or both of the alarm channel outputs to provide the following alarm output configurations:

Alarm 2      Temp < -40 Alarm 2 = ON

Temp > -40 Alarm 2 = OFF

Section 3.3.2 describes the method for reversing the default switching logic and Section 3.3.3 describes the method for setting up individual alarm set-points.

#### 3.3.2 Reversal of Alarm Switching Logic

As described in Section 3.3.1, the switching logic for the alarm channel may, if required, be reversed.

Starting at the default state, the method of reversing the switching logic for the alarm is as follows:

1. Press the **P** key once and the display will read **tECH**.
2. Press the **SET** key and the display will flash between **ConF** and **PinP**.
3. Press the  $\Rightarrow$  key three times and the display will flash between **ConF** and **Alr2**.
4. Press the **SET** key twice to display **Alt2**.
5. Press the  $\Rightarrow$  key once to display a flashing 4 digit number. For the Alarm 2 default setting this will be 0000.
6. Press the  $\Rightarrow$  key once to change the display to 0001.
7. Press the **SET** key to store the new value.
8. Press the **P** key twice to return.

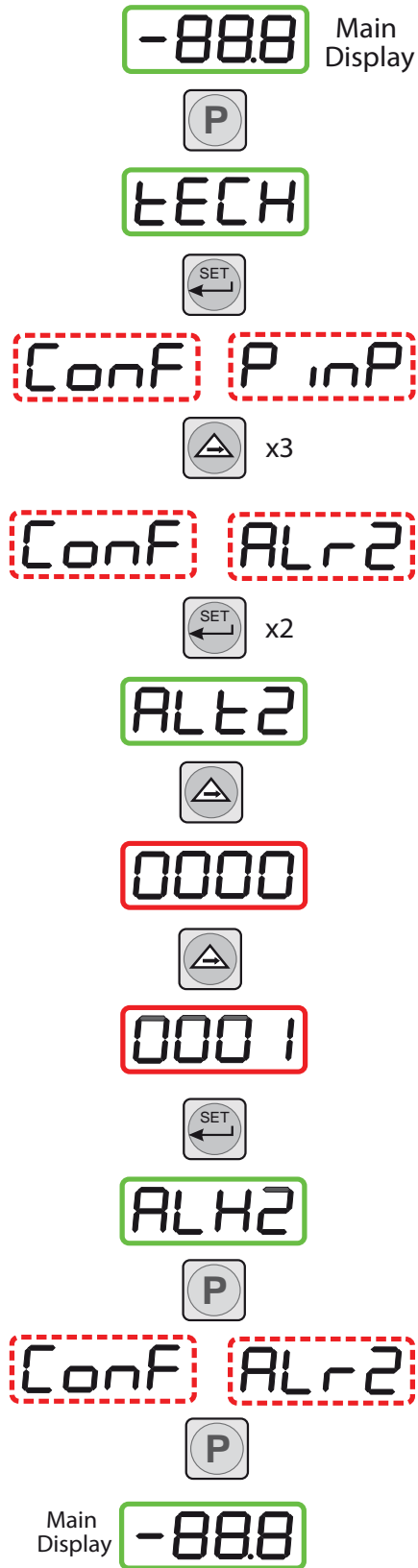

Figure 8 Change Alarm Switching Logic

### 3.3.3 Alarm Level Set-Up

The alarm set-point levels are set-up from the program menu as follows (to exit to the Main Display without saving any new settings press the P key):

Figure 9 shows the operational key sequence.

#### To set-up the alarm set-point:

1. Press the **SET** key twice.
2. Press the  $\Rightarrow$  key to display the flashing current Alarm 2 set-point (-40°C in this example).
3. Use the  $\Rightarrow$  or  $\Leftarrow$  keys to set the required value (-50°C in this example).
4. Press the **SET** key once to store the new value for Alarm 2. The display then returns to the main dew-point temperature display.

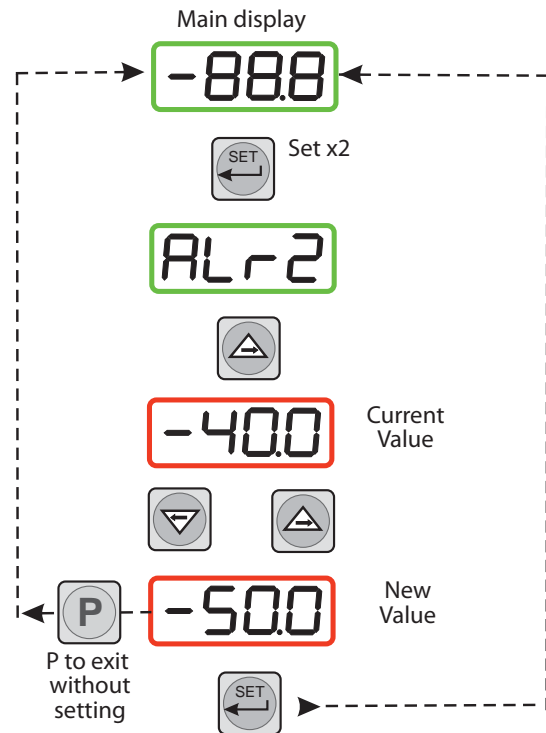

Figure 9 Set-up Alarm Levels

3.3.4 Re-Transmitted Output Current Range Set-Up

The Easidew DryCheck is provided with an analog current loop output module which buffers and re-transmits the current loop input signal from the dew-point transmitter.

By default, the re-transmission output is set as a 4-20 mA current loop (to exactly follow the input signal, i.e. 4 mA in, 4 mA out).

For certain system processes, a 0-20 mA current loop output may be required. The set-up method is as follows:

Figure 10 shows the operational key sequence.

**Change output from 4-20 mA to 0-20 mA**

1. Press the **P** key once, the display will read **tECH**.
2. Press the **SET** key and the display will flash between **ConF** and **PinP**.
3. Press the  $\Rightarrow$  key and the display will flash between **out1** and **ConF**.
4. Press the **SET** key to display **oAt1**.
5. Press the  $\Rightarrow$  key once to display a flashing 4 digit number. For the default setting (4-20 mA) this will be 0001.
6. Press the  $\Leftarrow$  key once to change the display to 0000. This selects the re-transmission output to be 0-20 mA.
7. Press the **SET** key to accept the new value. The output current loop is now 0-20 mA. The display will flash between **out1** and **ConF**.
8. Press the **P** key once to return to the main dew-point temperature display.

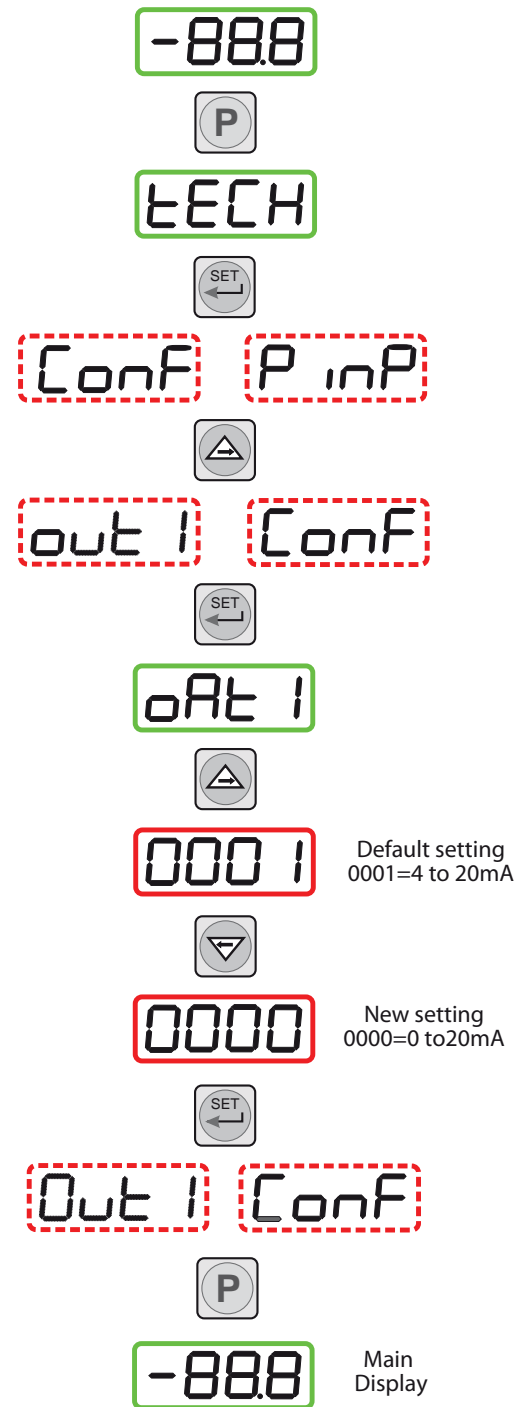

Figure 10 Configure Analog Output

**NOTE: The transmitter current loop output signal is now scaled at 6 mA per °C input, while the transmitter input remains scaled at 7.5°C per mA.**

### 3.4 Operating Temperature / ppm<sub>v</sub> Range

#### 3.4.1 Temperature Range Default

The default temperature unit for the Easidew DryCheck is in degrees Celsius. This is indicated by the °Cdp LED indicator. The default settings associated with this temperature scale are as follows:

- Span -100 to +20°Cdp
- Lower and upper span limits -100 and +20 (display flashes outside this range)
- Minimum alarm set-point -100°Cdp
- Maximum alarm set-point +20°Cdp



**To range the instrument for °F, all the above parameters need to be changed to their Fahrenheit equivalent values (-148 and +68°F). It is not sufficient just to change the °F/°C units.**

To change the range to Fahrenheit follow the procedures in Section 3.4.2.

3.4.2 Span and Unit Settings

To change the span and unit settings, proceed as follows. *Figure 11* shows the operational key sequence.

1. Press the **P** key once, the display will read **tECH**.
2. Press the **SET** key six times and the display will read **tPoL**.
3. Press the  $\Rightarrow$  key and the display will flash with the current minimum span limit (-100.0).
4. Use the  $\Rightarrow$  or  $\Leftarrow$  keys to set the required equivalent Fahrenheit value (-148.0) and press the **SET** key. **tPoH** is then displayed.
5. Press the  $\Rightarrow$  key, the display will flash the current maximum span limit (020.0).
6. Use the  $\Rightarrow$  or  $\Leftarrow$  keys to set the required equivalent Fahrenheit value (068.0) and press the **SET** key twice. **unit** is then displayed.
7. Press the  $\Rightarrow$  key, the display will flash the current unit ( $^{\circ}$ C).
8. Use the  $\Rightarrow$  or  $\Leftarrow$  keys to set the required scale units ( $^{\circ}$ F in this example) and press the **SET** key. **LoL** is then displayed.
9. Press the  $\Rightarrow$  key and the display will flash with the current alarm lower range limit (-100.0).
10. Use the  $\Rightarrow$  or  $\Leftarrow$  keys to set the required equivalent Fahrenheit value (-148) and press the **SET** key. **uPL** is then displayed.
11. Press the  $\Rightarrow$  key, the display will flash the current alarm upper range limit (020.0).
12. Use the  $\Rightarrow$  or  $\Leftarrow$  keys to set the required equivalent Fahrenheit value (068.0) and press the **SET** key. **PUoF** is then displayed.
13. Press the **P** key twice to return to the Main Display.

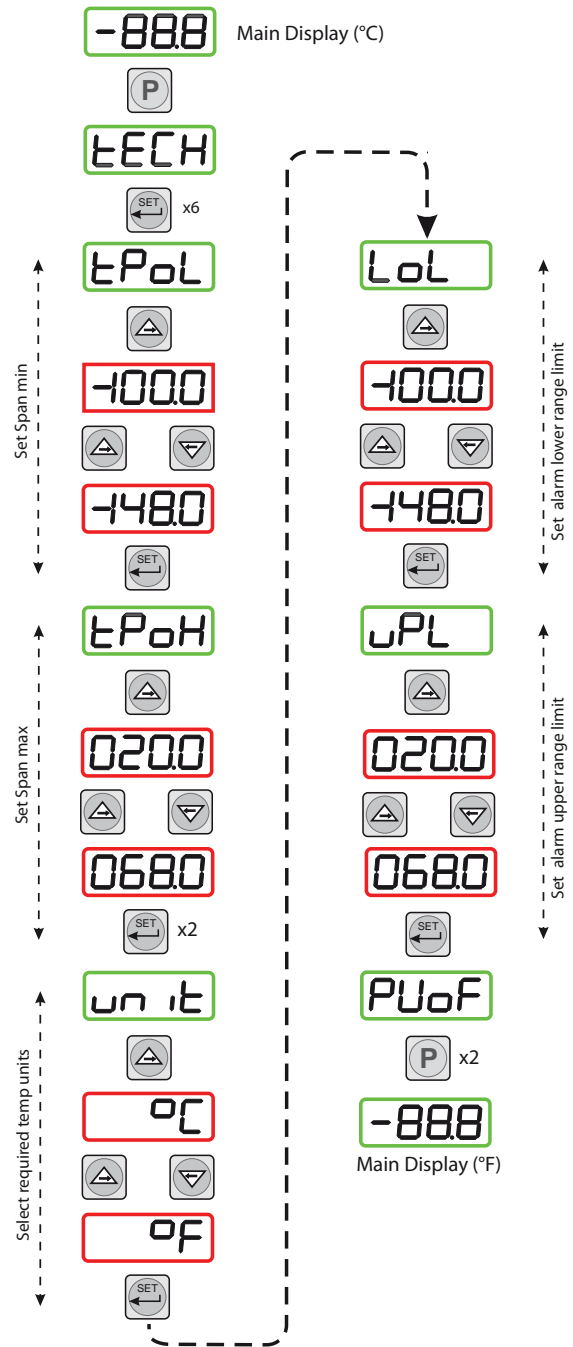

Figure 11 Span and Unit Settings

The maximum and minimum alarm level limits should now be changed to suit the new (Fahrenheit) unit values (refer to Section 3.4.3).

3.4.3 Alarm Set-Point Limit Configuration

The following procedure is used to set limits to which the alarm levels can be set (usually after re-configuring the instrument's range for Fahrenheit readings).

Figure 12 shows the operational key sequence.

1. Press the **P** key once, the display will read **tECH**.
2. Press the **SET** key once and the display will flash between **ConF** and **PinP**.
3. Press the  $\Rightarrow$  key four times and the display will flash between **ConF** and **GEnn**.
4. Press the **SET** key once, the display will read **SU-L**.
5. Press the  $\Rightarrow$  key once to display a flashing 4 digit number representing the current minimum alarm level setting. (The default setting for the °C range is -100.0).
6. Use the  $\Rightarrow$  or  $\Leftarrow$  keys to set the required new value (e.g. -148.0).
7. Press the **SET** key to accept the new value. The display will read **SU-u**.
8. Press the  $\Rightarrow$  key once to display a flashing 4 digit number representing the current maximum alarm level setting. (The default setting for the °C range is 020.0)
9. Use the  $\Rightarrow$  or  $\Leftarrow$  keys to set the required new value (e.g. 068.0).
10. Press the **SET** key to accept the new value, followed by the **P** key to return to the Main Display.

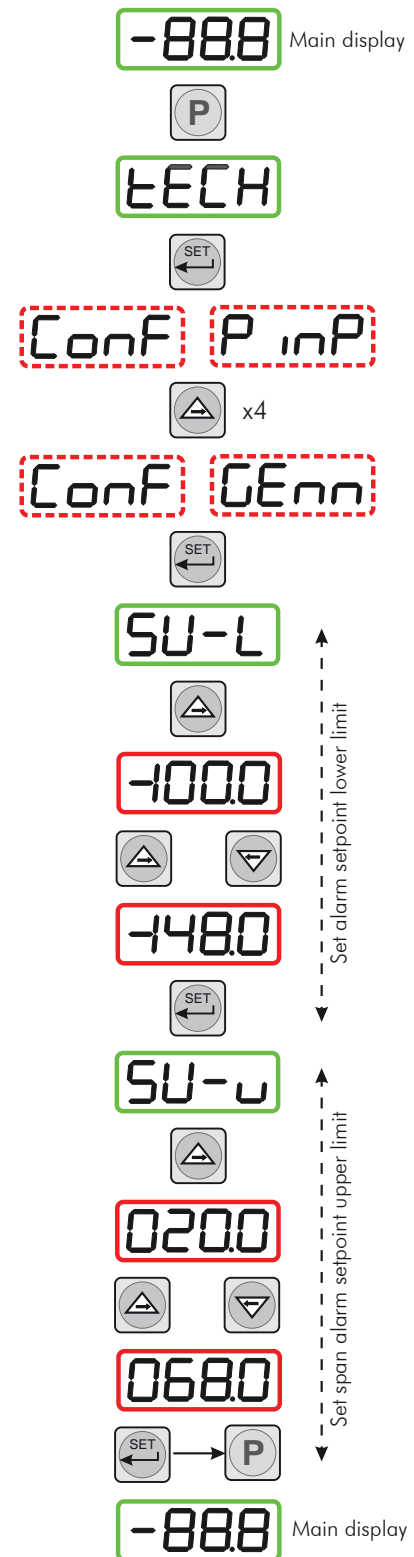

Figure 12 Set-up Alarm Set-Point Limits

### 3.4.4 Scale Units to ppm<sub>v</sub> Set-Up

To change the monitor to read parts per million by volume (ppm<sub>v</sub>) proceed as follows:

*Figure 13* shows the operational key sequence.

**NOTE: The dew-point transmitter must be configured to provide an output proportional to ppmV which can be set up at the time of order or by using the Michell application software. Contact Michell Instruments for information (for contact details see [www.michell.com](http://www.michell.com)).**

1. Press the **P** key once, the display will read **tECH**.
2. Press the **SET** key four times and the display will read **dPnt**.
3. Press the  $\Rightarrow$  key, the display will flash the current decimal point position (0001).
4. Press the  $\Leftarrow$  key to set 0000 on the display (no decimal point), and press the **SET** key twice. **tPoL** is then displayed.
5. Press the  $\Rightarrow$  key, the display will flash the current minimum span limit (-1000)
6. Use the  $\Rightarrow$  or  $\Leftarrow$  keys to set the required ppm<sub>v</sub> minimum reading (0000) and press the **SET** key. **tPoH** is then displayed.
7. Press the  $\Rightarrow$  key, the display will flash the current maximum span limit (0200).
8. Use the  $\Rightarrow$  and  $\Leftarrow$  keys to set the required ppm<sub>v</sub> maximum reading (3000) and press the **SET** key twice. **unit** is then displayed.
9. Press the  $\Rightarrow$  key, the display will flash the current unit (°C).
10. Press the  $\Rightarrow$  key three times to set the display reading to `\_' (ppm<sub>v</sub>) and press the **SET** key. **LoL** is then displayed.
11. Press the  $\Rightarrow$  key, the display will flash the current alarm lower range limit (-1000) (formerly -100.0 with no sign or decimal point showing).
12. Use the  $\Rightarrow$  or  $\Leftarrow$  keys to set the required alarm lower range limit (point where display starts to flash) (0 or different value), and press the **SET** key. **uPL** is then displayed.
13. Press the  $\Rightarrow$  key, the display will flash the current alarm upper range limit (0200) (formerly 020.0 with no decimal point showing).
14. Use the  $\Rightarrow$  or  $\Leftarrow$  keys to set the required alarm upper range limit (point where display starts to flash) (3000 or different value), and press the **SET** key. **PUoF** is now displayed.
15. Press the **P** key twice and the Main Display, now reading ppm<sub>v</sub> will show.  
**NOTE: Neither the °C nor the °F LED indicators on the front panel of the monitor are now lit.**

On completion of the above procedure, appropriate alarm levels (relevant to the new ppm<sub>v</sub> scale) will need to be set-up (refer to Section 3.4.3).

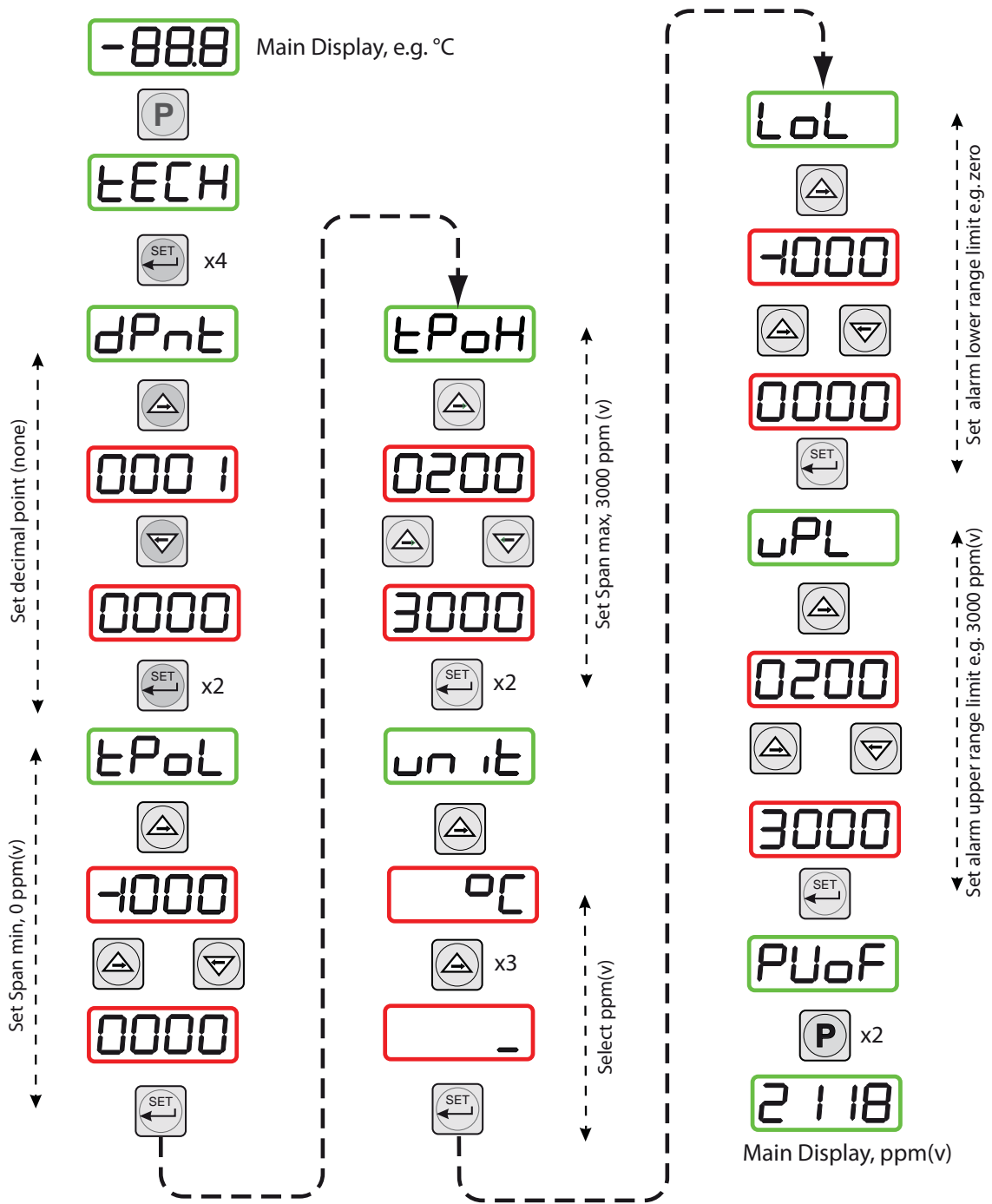

Figure 13 Set-up Monitor (to read ppm<sub>v</sub>)

**3.4.5 Monitor Limits When Unit Scaled to ppm<sub>v</sub>**

When unit is scaled to ppm<sub>v</sub> the display will read zero when the mA input signal is between 3 and 4 mA.

### 3.5 Digital Communication Parameters Set-Up

The default parameters for the Easidew Drycheck are as follows:

Default Address = 1, Baud rate = 9600, Parity = None, Stop bits = 1

To change these parameters, proceed as follows:

*Figure 14* shows the operational key sequence.

1. Press the **P** key once, the display will read **tECH**.
2. Press the **SET** key and the display will flash between **ConF** and **PinP**.
3. Press the  $\Rightarrow$  key five times, the display will flash between **ConF** and **Corn**.

#### Set-up instrument address

4. Press the **SET** key once to display **SAdr**.
5. Press the  $\Rightarrow$  key once to display a flashing 4 digit number. The default setting is 0001.
6. Use the  $\Rightarrow$  or  $\Leftarrow$  keys to give the required new value (e.g. 0002). **NOTE: The range of possible addresses is between 1 and 247.** Press the **SET** key to accept the new value.

#### Set baud rate

7. **bAud** will now be displayed. Press the  $\Rightarrow$  key once to display a flashing 4 digit number. The default setting is 0003, representing 9600 baud.
8. Use the  $\Rightarrow$  and  $\Leftarrow$  keys to give the required new value (the range is 0 to 4). 0 = 1200 baud, 1 = 2400 baud, 2 = 4800 baud, 3 = 9600 baud, 4 = 19200 baud. Press the **SET** key to accept the selected value.

#### Set parity

9. **Prty** will now be displayed. Press the  $\Rightarrow$  key once to display a flashing 4 digit number. The default setting is 0000, representing no parity (none).
10. Use the  $\Rightarrow$  or  $\Leftarrow$  keys to give the required new value (the range is 0 to 2). 0 = none, 1 = Odd, 2 = Even. Press the **SET** key to accept the selected value.

#### Set number of stop bits

11. **StPb** will now be displayed. Press the  $\Rightarrow$  key once to display a flashing 4 digit number. The default setting is 0000, representing 1 stop bit.
12. Use the  $\Rightarrow$  or  $\Leftarrow$  keys to give the required new value (the range is 0 - 1) 0 = 1 stop bit, 1 = 2 stop bits.
13. Press the **SET** key to accept the selected value, followed by the **P** key to return to the Main Display.

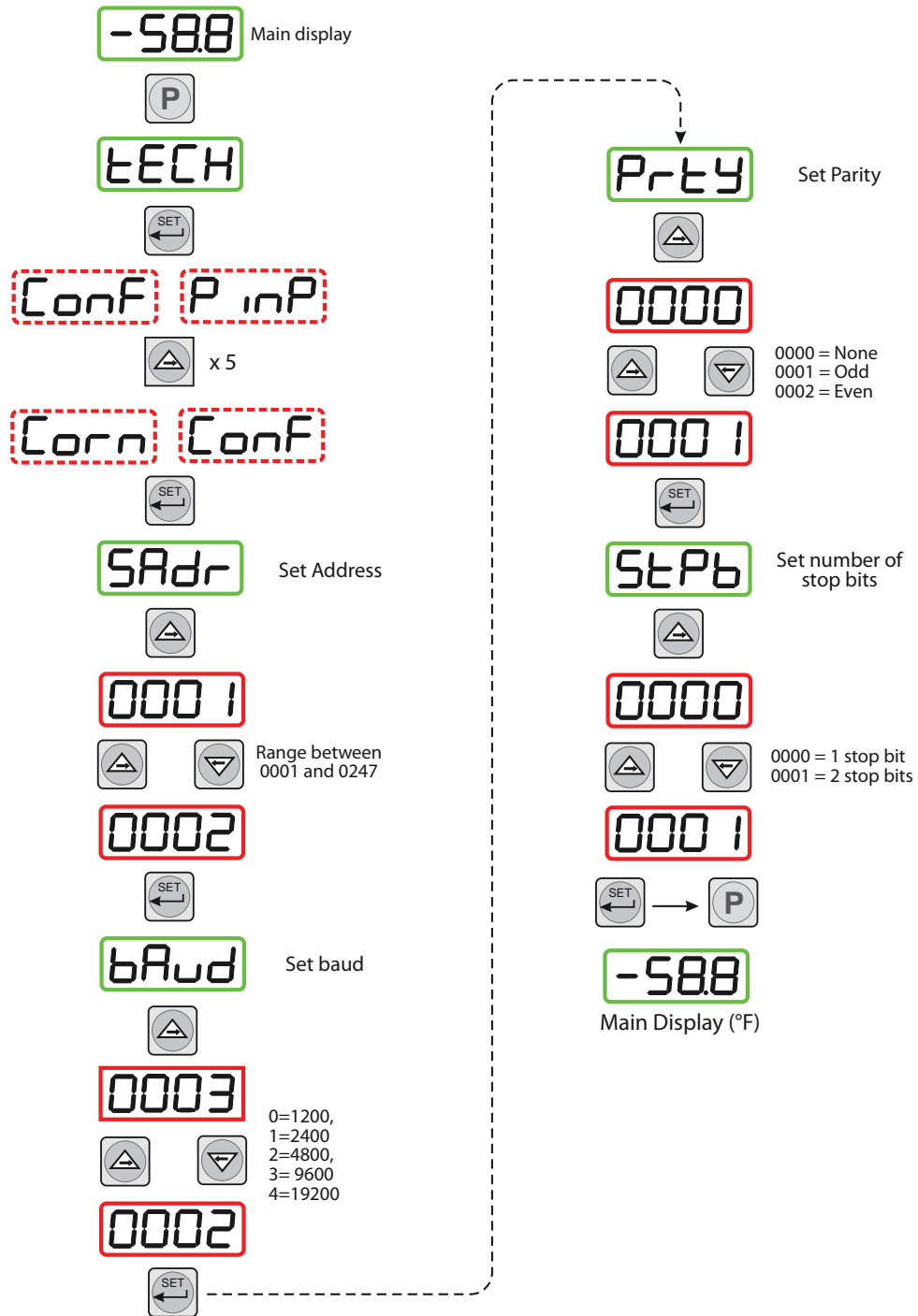

Figure 14 Set-up Data Communications Parameters

### 3.6 Monitor – Reading the Displayed Value Using Modbus RTU Over RS232

It is possible to communicate with the online monitor using Modbus RTU over RS232. The monitor has a three pin serial port connection on the back – the required cable can be supplied by Michell.

To read the value displayed on the monitor a byte array must be created, containing the following bytes:

Instrument Address	Command	Reg Address High	Reg Address Low	Number of Reg High	Number of Reg Low	LRC	CRC
0x01	0x04	0x00	0x00	0x00	0x01	0x31	0xCA

Send this to the instrument with the correct delays between characters:

Baud Rate (bps)	Min Delay (ms)	Max Delay (ms)
1200	9.17	13.76
2400	4.59	6.88
4800	2.30	3.44
9600	1.15	1.72
19200	0.57	0.86

After a few seconds the instrument will send back the following response:

Instrument Address	Command	Number of bytes	Display High	Display Low	LRC	CRC
0x01	0x03	0x02	0x00	0x67	(Varies)	(Varies)

Data MSB \* 256 + Data LSB = 0 \* 256 + 103 = 103

This code, written in c, can be used to convert the 103 into a real dew-point value or 10.3:

```
float ConvertToReal(int Value) //convert dew-point value to real dew-point result
{
    float result; //declaration
    if (Value > 32767) Value=(Value-65536); //convert to negative number
    result = (float)(Value/10.0); //divide number by 10 to convert to float
    return result; //return real value}
}
```

## 4 GOOD MEASUREMENT PRACTICE

The Easidew DryCheck is designed to operate in a flowing gas stream and is suitable for the measurement of the moisture content of a wide variety of gases. In general, if the gas (in conjunction with water vapor) is not corrosive to ceramics or base metals then it will be suitable for measurement by the Easidew DryCheck.

The system is designed for operation with sample gas flow rates of 1 to 5 NI/min (2.1 to 10.6 scfh) (sample block). Ideally, the flow rate should be set-up between 4 and 6 NI/min. Flow regulation is provided within the Easidew DryCheck system. Always use high quality valve gear, coupling connections and pipework.

The system will operate successfully at flow rates within its operational range and it is important to ensure that the flow rate through the sample block is high enough to avoid long time lags in response to humidity changes at the sample source.

Avoid pressure gradients in the system by placing excessive flow restriction on the output side of the sample block. In applications where the test gas has a very high flow rate, an instrument by-pass arrangement is preferable to flow restriction after the transmitter.

### Flow Rates

Theoretically flow rate has no direct effect on the measured moisture content, but in practice it can have unanticipated effects on response speed and accuracy.

An inadequate flow rate can:

- Accentuate adsorption and desorption effects on the gas passing through the sampling system.
- Allow pockets of wet gas to remain undisturbed in a complex sampling system, which will then gradually be released into the sample flow.
- Increase the chance of contamination from back diffusion: ambient air that is wetter than the sample can flow from the exhaust back into the system. A longer exhaust (sometimes called a pigtail) can also help alleviate this problem.
- Slow the response of the sensor to changes in moisture content.

An excessively high flow rate can:

- Introduce back pressure, causing slower response times and unpredictable effects on equipment such as humidity generators.

### Factory Flow Rate Setting

Internally the gas enters a sample block at which point an adjustable flow valve is located. This valve is factory set to output 2.5 l/min flow at 7 barg.

## 5 MAINTENANCE

### 5.1 General Maintenance Guidelines

Routine maintenance of the Easidew DryCheck is confined to filter element replacement and regular recalibration of the dew-point transmitter.

### 5.2 Calibration

Routine maintenance of the transmitter is confined to regular re-calibration by exposure of the transmitter to sample gases of known moisture content to ensure that the stated accuracy is maintained. Calibration services traceable to the UK National Physical Laboratory (NPL) and the US National Institute of Standards and Technology (NIST) are provided by Michell Instruments.

Michell Instruments offers a variety of re-calibration and exchange sensor schemes to suit specific needs. A Michell representative can provide detailed, custom advice (for Michell Instruments' contact information go to [www.michell.com](http://www.michell.com)).

### 5.3 Transmitter Maintenance

To replace the transmitter proceed as follows:



**Always de-pressurize the system and disconnect any electronic supplies before commencing maintenance.**

1. Open the transparent front cover.
2. Remove the four screws securing the aluminum front panel.
3. Carefully lift the front panel to expose the transmitter.
4. Remove the electrical mini DIN connector from the transmitter by loosening the connector-securing screw and pulling it away from the transmitter.
5. Unscrew the transmitter from the block using a 27AF spanner/wrench.
6. Fit a new transmitter and fully tighten to a minimum torque of 30.5Nm.
7. Repeat the above instructions in reverse order.

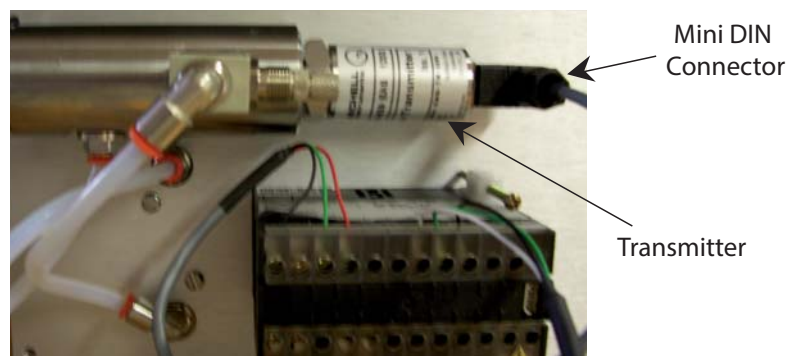

Figure 15 *Sensor Removal*

## 5.4 Inspection/Cleaning

The composition of the gas determines the frequency of the filter element replacement, i.e. liquid and particulate contaminants, corrosive elements, etc.

A disposable filter element continues to filter at its original efficiency as long as it is kept in service. The life of the element is determined by the increase in flow resistance caused by trapped solids in the element. The element should be changed when the flow falls below an acceptable level, or the pressure drop becomes too high. In any case the element should be replaced before the pressure drop across it reaches 0.7 barg (10.2 psig).

To replace a particulate filter element (Michell part SSF-PF-10PK (pack of 10)), proceed as follows:



**Always de-pressurize the system and disconnect any electronic supplies before commencing maintenance.**

1. Unscrew the stainless steel cap and withdraw it from the block.
2. The filter is a push-fit onto a mounting boss. To remove, pull apart from the cap.
3. Refit a new element. **NOTE: Do not touch the element with bare fingers.**

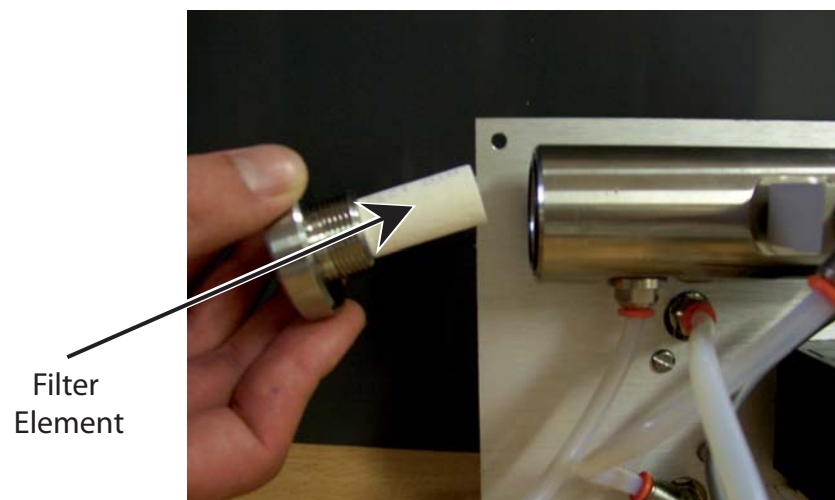

Figure 16 *Inspection/Cleaning*

## 5.5 Fault Conditions

Message Displayed	Cause	Action
<b>ErrL</b>	Sensor failure	Check power supply to transmitter. Check transmitter cable for continuity/damage. Rectify/replace cable.
	Instrument failure	Refer to Michell or local representative for repair.
<b>Sbr</b>	Sensor failure or break in sensor connection	Check transmitter cable for continuity/damage. Rectify/replace cable.
<b>ErrH</b>	Gas is wetter than +20°Cdp	Check gas source supply.
	Sensor contaminated	Replace/re-calibrate transmitter.
<b>outR</b>	Input out of range	Check gas source supply. Re-calibrate/replace transmitter.
<b>rurC</b>	Reverse input connection	Swap input connections from the transmitter to the monitor.

# Appendix A

## Technical Specifications

## Appendix A Technical Specifications

<b>-100 to +20°Cdp</b>	
<b>Electrical Specifications</b>	
Power Supply	85 to 265 V AC, 50/60 Hz
<b>Operating Specifications</b>	
Operating Temperature	-5 to +50°C (+23 to +122°F)
Storage Temperature	-40 to +75°C (-40 to +167°F)
Measurement Range	-100 to +20°Cdp (-148 to +68°F) 3000 ppm <sub>v</sub> (ppm <sub>v</sub> output or non-standard dew-point range must be specified at time of order)
Accuracy	±2°Cdp
Output	4-20 mA maximum load resistance 500 Ω
Alarm	2 volt free contacts 240 V, 3A
Sample Flow Rate	1 to 5 NI/min (2.1 to 10.6 scfh)
Gas Pressure	1 MPa (10 barg/145 psig) max (high pressure option available)
<b>Mechanical Specifications</b>	
User Interface	Front panel configuration of alarm points
Display	20mm (¾") red LED
Ingress Protection	IP65 (NEMA 4x)
Mains Cable	2m cable supplied
Filtration	99.5% removal of 0.3µm
Gas Connection	Quick connect fittings for 6mm (¼") OD Teflon pipe

<b>-60 to +60°Cdp / -50 to +50°Cdp</b>	
<b>Electrical Specifications</b>	
Power Supply	85 to 265 V AC, 50/60 Hz
<b>Operating Specifications</b>	
Operating Temperature	-5 to +50°C (+23 to +122°F)
Storage Temperature	-40 to +75°C (-40 to +167°F)
Measurement Range	-60 to +60°Cdp (-76 to 140°Fdp) / -50 to +50°Cdp (-58 to +122°Fdp) Non-standard available on request
Accuracy	±2°Cdp
Output	4-20 mA maximum load resistance 500 Ω
Alarm	2 volt free contacts 240 V, 3A
Sample Flow Rate	1 to 5 NI/min (2.1 to 10.6 scfh)
Gas Pressure	1 MPa (10 barg/145 psig) max (high pressure option available)
<b>Mechanical Specifications</b>	
User Interface	Front panel configuration of alarm points
Display	20mm (¾") red LED
Ingress Protection	IP65 (NEMA 4x)
Mains Cable	2m cable supplied
Filtration	99.5% removal of 0.3µm
Gas Connection	Quick connect fittings for 6mm (¼") OD Teflon pipe

# Appendix B

## System Drawing

Appendix B System Drawing

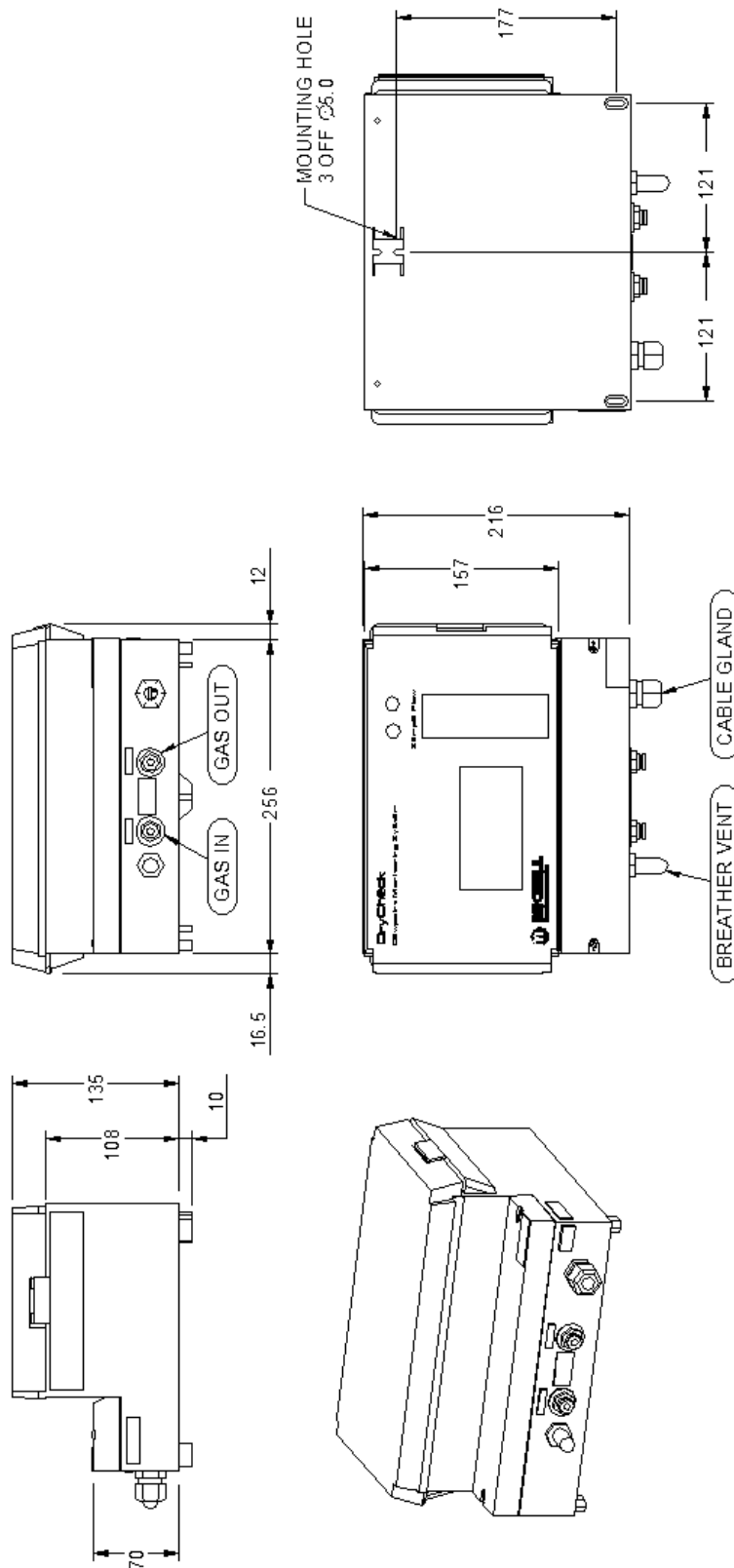

Figure 17 System Drawings

# Appendix C

## Quality, Recycling & Warranty Information

## Appendix C    Quality, Recycling & Warranty Information

Michell Instruments is dedicated to complying to all relevant legislation and directives. Full information can be found on our website at:

**[www.michell.com/compliance](http://www.michell.com/compliance)**

This page contains information on the following directives:

- ATEX Directive
- Calibration Facilities
- Conflict Minerals
- FCC Statement
- Manufacturing Quality
- Modern Slavery Statement
- Pressure Equipment Directive
- REACH
- RoHS2
- WEEE2
- Recycling Policy
- Warranty and Returns

This information is also available in PDF format.

# Appendix D

## Return Document & Decontamination Declaration

Appendix D Return Document & Decontamination Declaration

**Decontamination Certificate**

**IMPORTANT NOTE:** Please complete this form prior to this instrument, or any components, leaving your site and being returned to us, or, where applicable, prior to any work being carried out by a Michell engineer at your site.

Instrument			Serial Number	
Warranty Repair?	YES	NO	Original PO #	
Company Name			Contact Name	
Address				
Telephone #			E-mail address	
Reason for Return /Description of Fault:				
Has this equipment been exposed (internally or externally) to any of the following? Please circle (YES/NO) as applicable and provide details below				
Biohazards			YES	NO
Biological agents			YES	NO
Hazardous chemicals			YES	NO
Radioactive substances			YES	NO
Other hazards			YES	NO
Please provide details of any hazardous materials used with this equipment as indicated above (use continuation sheet if necessary)				
Your method of cleaning/decontamination				
Has the equipment been cleaned and decontaminated?			YES	NOT NECESSARY
Michell Instruments will not accept instruments that have been exposed to toxins, radio-activity or bio-hazardous materials. For most applications involving solvents, acidic, basic, flammable or toxic gases a simple purge with dry gas (dew point <-30°C) over 24 hours should be sufficient to decontaminate the unit prior to return. <b>Work will not be carried out on any unit that does not have a completed decontamination declaration.</b>				
<b>Decontamination Declaration</b>				
I declare that the information above is true and complete to the best of my knowledge, and it is safe for Michell personnel to service or repair the returned instrument.				
Name (Print)			Position	
Signature			Date	



# EU Declaration of Conformity



Manufacturer: **Michell Instruments Limited**  
**48 Lancaster Way Business Park**  
**Ely, Cambridgeshire**  
**CB6 3NW. UK.**

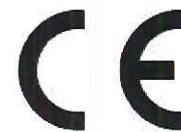

On behalf of the above named company, I declare that, on the date that the equipment accompanied by this declaration is placed on the market, the equipment conforms with all technical and regulatory requirements of the listed directives.

## DryCheck

and complies with all the essential requirements of the EC directives listed below.

**2004/108/EC**      **EMC Directive**  
**2006/95/EC**      **Low Voltage Directive (LVD)**

and (effective from 20<sup>th</sup> April 2016)

**2014/30/EU**      **EMC Directive**  
**2014/35/EU**      **Low Voltage Directive (LVD)**

and (effective from 22<sup>nd</sup> July 2017)

**2011/65/EU**      **Restriction of Hazardous Substances Directive (RoHS2)**

RoHS2 EU Directive 2011/65/EU (Article 3, [24]) states, "*industrial monitoring and control instruments means monitoring and control instruments designed exclusively for industrial or professional use*". (mandatory compliance effective date 22<sup>nd</sup> July 2017).

and has been designed to be in conformance with the relevant sections of the following standards or other normative documents.

EN61326-1:1997      Electrical equipment for measurement, control and laboratory use –  
EMC requirements –Class A (emissions)[Monitor] Class B  
(emissions) [Sensor] and Industrial Locations (immunity).

EN61010-1:2010      Safety Requirements for Electrical Equipment for  
Measurement, Control, and Laboratory Use - Part 1:  
General Requirements

Andrew M.V. Stokes, Technical Director

Jan 2016



Instrument Expert  
Original factory  
packaging  
[www.keruiyiqi.cn](http://www.keruiyiqi.cn)



<http://www.michell.com>